

VUE-2150

15.0" Square PCAP Touch Monitor

Preliminary



Features

- 15.0" active screen size (Square)
- Full-flat cover glass for extremely simple surface design
- Anti-glare (AG) treatment on screen for comfortable viewing experience
- Built-in multiple I/O interfaces for diverse media connectivity
- Adopts industrial-grade components for guaranteed performance
- Mount with multi-way and easy to extend peripheral devices (box PC/camera...)
- Front IP65 water-proof rating and IK08 high-level impact protection
- Support 10-point touch function (PCAP technology)
- Excellent noise immunity well-suited for rugged applications (CS 10V)
- Support many touch method including fingers, glove, and stylus

Specifications

Brand	Advantech			
Display	Active Screen Size	15.0 inch		
	Resolution	1024 x 768 (XGA)		
	Brightness	500nits (Typ.)		
	Contrast Ratio	2500:1 (Typ.)		
	Aspect Ratio	4:3 (Square)		
	Viewing Angle	88° / 88° / 88° / 88°		
	Response Time	13ms (Typ.)		
	Backlight Life (hours)	70,000 (Typ.)		
Touch	Touch Type	Projected Capacitive Touch (PCAP)		
	Touch Function	10 points		
	Touch Interface	USB		
	Touch Method	Finger/Glove		
	Stylus Pen	Active Stylus (optional accessory)		
Connectivity	Input	Video	VGA x 1, HDMI x 1, DisplayPort x 1	
		Audio	Audio line in x 1	
		Control	D-SUB-9 x 1 for external Function key	
		Other slots/ports	USB typeB for touch	
	Output	Video	N/A	
		Audio	3W+3W Internal Speaker	
	Control	N/A		
System	OS	N/A		
	CPU	N/A		
	Memory	N/A		
	OSD Language	English, Simplified Chinese, Traditional Chinese		
	OSD Function	AUTO/UP/DOWN/MENU		
Power	Power Type	External Adapter, AC to DC, 12V		
	Power Input-AC	100-240VAC, 50-60Hz, 1A		
	Power Consumption	18W (Typ.)		
Environment	Operating	Temperature	-20°C ~ 50°C	
		Humidity	10% to 85% (non-condensing)	
	Storage	Temperature	-20°C- 50°C	
		Humidity	5% to 80% (non-condensing)	
Mechanical Specification	Housing Material	1.0 mm steel metal (Black), Aluminium bezel		
	Waterproof Rating	Front IP65		
	VESA CompatMBility	100 x 100 mm		
	Side mount screw hole	75 mm for bracket installation		
	Hand Hoder/Stand	Stand (optional accessory)		
	Cable Management	Yes, with cable organizer kit		
	Dimensions (W x H x D)	Physical without stand	359.1 x 285 x 46.2 mm	
		Packing	483 x 375 x 195 mm	
	Weight	Net	3.5Kg	
		Gross	5.5Kg	
Installation	Installation rotation	Landscape/Portrait		
	Mounting on a wall	100 x 100 mm, VESA grid		
	Mounting with stand/arm	100 x 100 mm, VESA grid		
	Mounting through bracket	75 mm, Side mount screw hole		
	Extending PC/peripherals	75 mm, Side mount screw hole		
Certificate	BSMI, CB, CCC, CE, FCC			
Warranty	2-year warranty (1-year for panel)			

Dimensions

Unit: mm

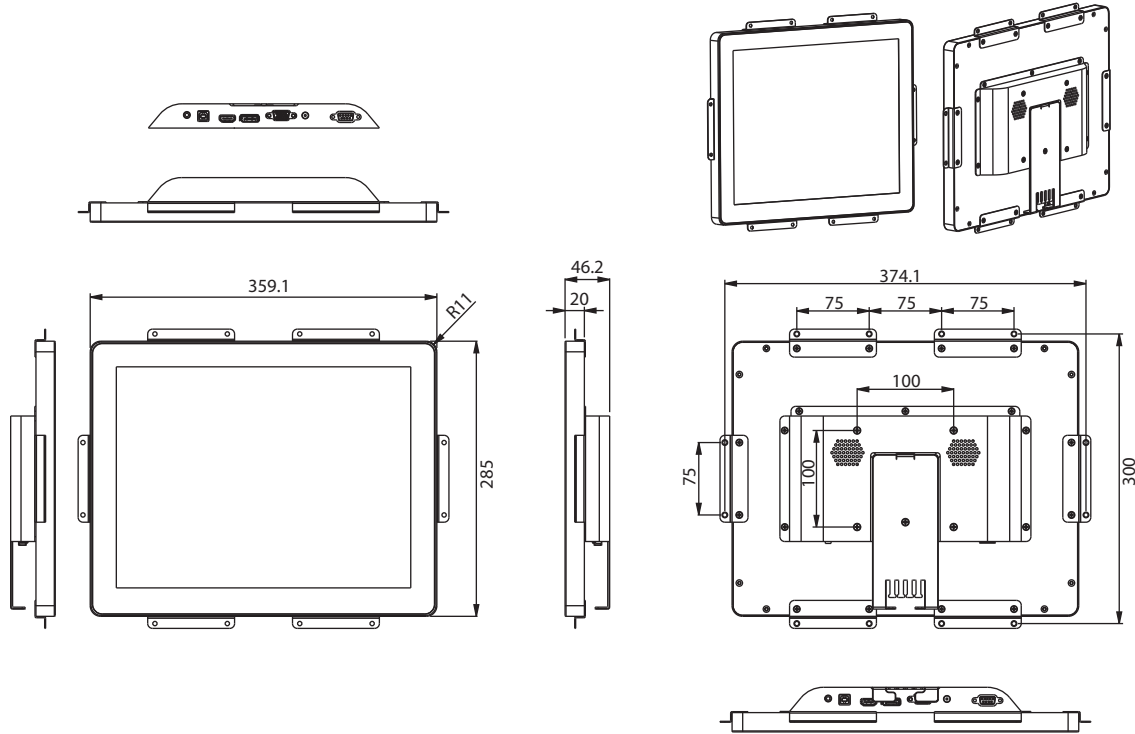

Ordering Information

Part Number	Description	Packing List
VUE-2150-XA50PA-N4	Advantech 15.0" XGA Panel Mount Monitor (incl. Europe, Taiwan, and US Power Cord)	<ul style="list-style-type: none"> ▪ Power Adapter (1.5M, Black) ▪ Power cord (1.5M, Black) ▪ VGA cable (1.5M, Black) ▪ HDMI cable (1.5M, Black) ▪ DisplayPort cable (1.5M, Black) ▪ Audio cable (1.5M, Black) ▪ USB cable (1.5M, Black), for touch function ▪ External control key pad ▪ Side mount bracket kit (Steel) ▪ Cable organizer kit (Aluminum) ▪ Startup manual (Paper)
VUE-2150-XA50PC-N4	Advantech 15.0" XGA Panel Mount Monitor (incl. Europe, Taiwan, and US Power Cord)	
VUE-2150-XA50PE-N4	Advantech 15.0" XGA Panel Mount Monitor (incl. Europe, Taiwan, and US Power Cord)	
VUE-2150-XA50PX-N4	Advantech 15.0" XGA Panel Mount Monitor (incl. Europe, Taiwan, and US Power Cord)	

Optional Accessories

Part Number	Description
960T-A15DEE-B0	Active Stylus Pen for VUE-2000 series, Black